

N-Channel MOSFET

MDD1904 (KDD1904)

■ Features

- $V_{DS} (V) = 100V$
- $I_D = 10.8 A (V_{GS} = 10V)$
- $R_{DS(ON)} < 140m\Omega (V_{GS} = 10V)$
- $R_{DS(ON)} < 150m\Omega (V_{GS} = 6V)$

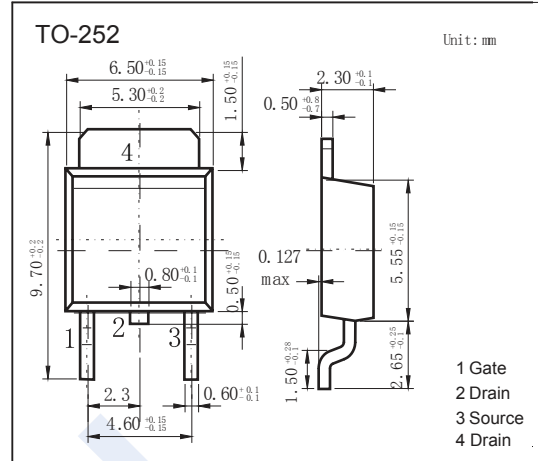
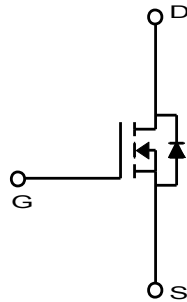

■ Absolute Maximum Ratings $T_a = 25^\circ C$

Parameter	Symbol	Rating	Unit
Drain-Source Voltage	V_{DS}	100	V
Gate-Source Voltage	V_{GS}	± 20	
Continuous Drain Current	I_D	$T_c=25^\circ C$	10.8
		$T_c=70^\circ C$	8.7
Pulsed Drain Current	I_{DM}	25	A
Single Pulse Avalanche Energy (Note.1)	EAS	12.5	mJ
Power Dissipation	P_D	$T_c=25^\circ C$	35.8
		$T_c=70^\circ C$	22.9
Thermal Resistance.Junction- to-Ambient	R_{thJA}	52	$^\circ C/W$
Thermal Resistance.Junction- to-Case	R_{thJC}	3.5	
Junction Temperature	T_J	150	$^\circ C$
Storage Temperature Range	T_{stg}	-55 to 150	

Note.1: EAS is tested at starting $T_J=25^\circ C$, $L=1mH$, $I_{AS}=5A$, $V_{DD}=50V$, $V_{GS}=10V$

N-Channel MOSFET

MDD1904 (KDD1904)

■ Electrical Characteristics Ta = 25°C

Parameter	Symbol	Test Conditions	Min	Typ	Max	Unit
Drain-Source Breakdown Voltage	V _{DSS}	I _D =250 μ A, V _{GS} =0V	100			V
Zero Gate Voltage Drain Current	I _{DSS}	V _{DS} =80V, V _{GS} =0V			1	μA
Gate-Body Leakage Current	I _{GSS}	V _{DS} =0V, V _{GS} =±20V			±100	nA
Gate Threshold Voltage	V _{GS(th)}	V _{DS} =V _{GS} , I _D =250 μ A	1		3	V
Static Drain-Source On-Resistance	R _{DS(on)}	V _{GS} =10V, I _D =8A			140	mΩ
		V _{GS} =6V, I _D =8A			150	
Forward Transconductance	g _{FS}	V _{DS} =10V, I _D =8A		13.5		S
Input Capacitance	C _{iss}	V _{GS} =0V, V _{DS} =25V, f=1MHz		355		pF
Output Capacitance	C _{oss}			16		
Reverse Transfer Capacitance	C _{rss}			51		
Total Gate Charge (10V)	Q _g	V _{GS} =10V, V _{DS} =50V, I _D =8A		6.7		nC
Gate Source Charge	Q _{gs}			1.3		
Gate Drain Charge	Q _{gd}			1.8		
Turn-On DelayTime	t _{d(on)}			6.7		
Turn-On Rise Time	t _r	V _{GS} = 10V, V _{DS} = 50V, I _D = 8A, R _G = 3Ω		3.6		ns
Turn-Off DelayTime	t _{d(off)}			13.7		
Turn-Off Fall Time	t _f			3.3		
Body Diode Reverse Recovery Time	t _{rr}			36.5		
Body Diode Reverse Recovery Charge	Q _{rr}	I _F = 8A, di/dt= 100A/μ s		58.5		nC
Maximum Body-Diode Continuous Current	I _S				8	A
Diode Forward Voltage	V _{SD}	I _S =8A, V _{GS} =0V			1.2	V

N-Channel MOSFET

MDD1904 (KDD1904)

■ Typical Characteristics

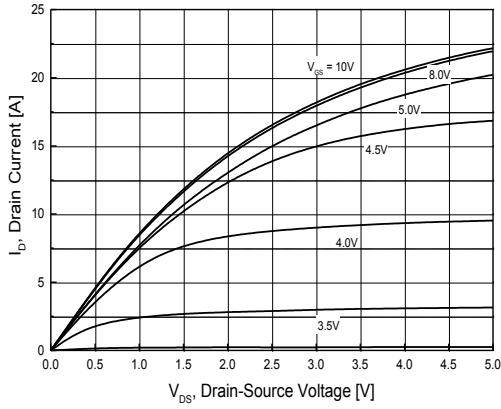

Fig.1 On-Region Characteristics

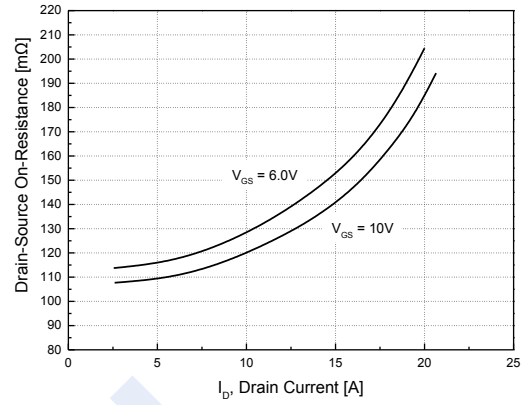

Fig.2 On-Resistance Variation with Drain Current and Gate Voltage

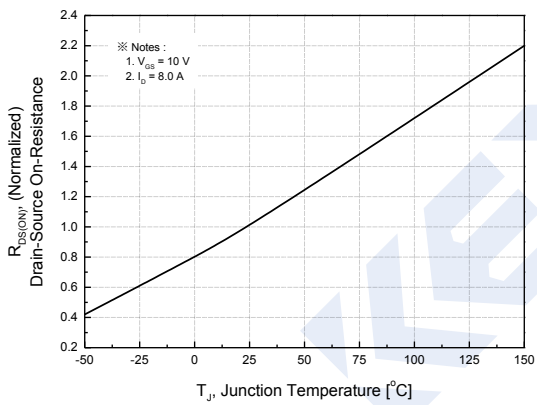

Fig.3 On-Resistance Variation with Temperature

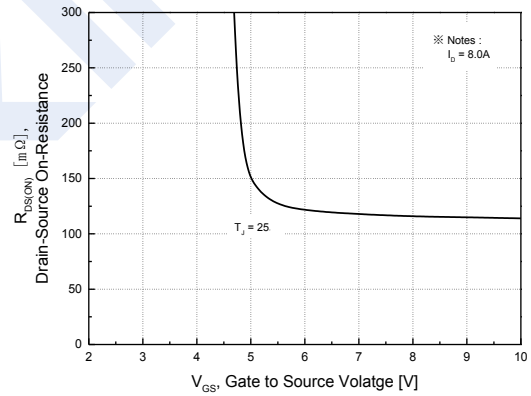

Fig.4 On-Resistance Variation with Gate to Source Voltage

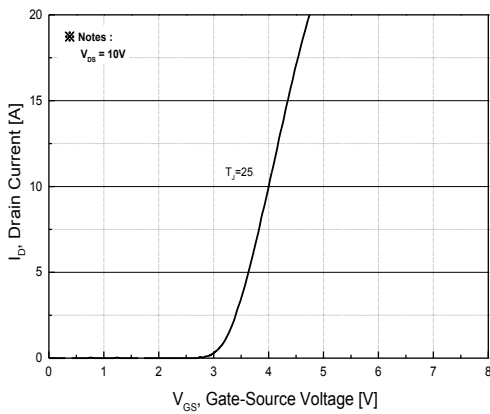

Fig.5 Transfer Characteristics

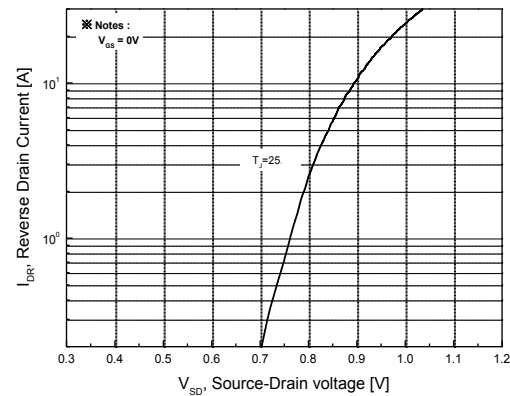

Fig.6 Body Diode Forward Voltage Variation with Source Current and Temperature

N-Channel MOSFET MDD1904 (KDD1904)

Typical Characteristics

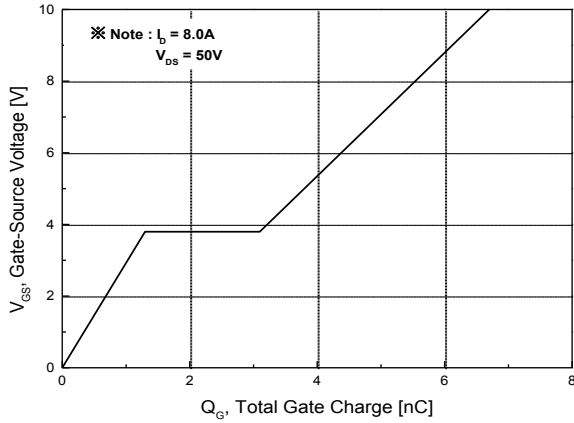

Fig.7 Gate Charge Characteristics

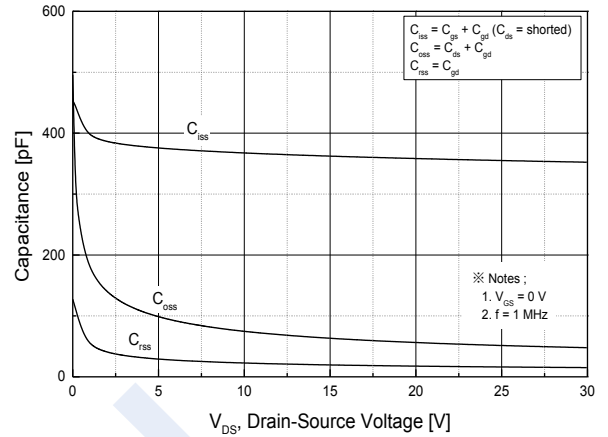

Fig.8 Capacitance Characteristics

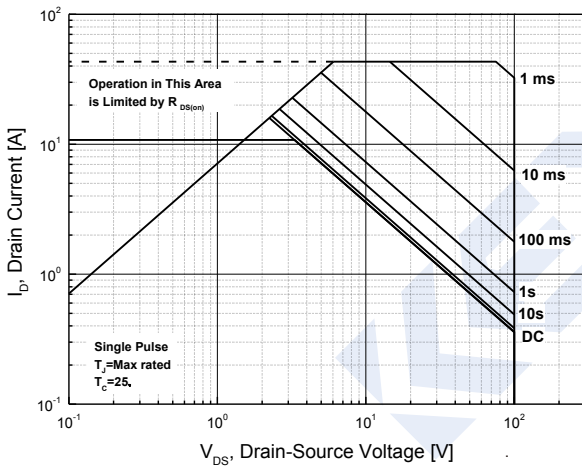

Fig.9 Maximum Safe Operating Area

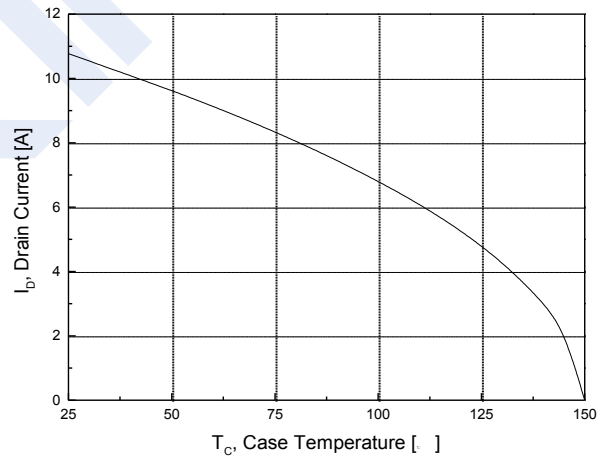

Fig.10 Maximum Drain Current vs. Case Temperature

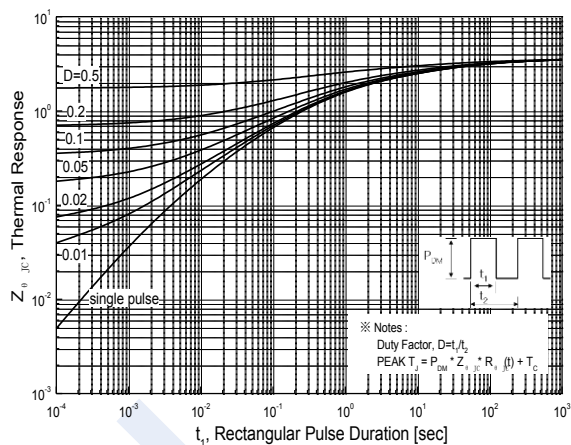

Fig.11 Transient Thermal Response Curve